

E-Mon D-Mon[®] Installation Manual

Class 2000 kWh & kWh/Demand Meter



Dear Valued Customer,

We are pleased that you chose to buy one of our products, and want you to be just as pleased with owning it. Before installing your new E-Mon product, please read the information on the following pages carefully.

We believe that you will find the E-Mon D-Mon meters easy to install and to use for monitoring and evaluating your electrical usage.

To be sure that you are 100% satisfied with your products, we provide toll-free technical and sales support Monday through Friday, 8:00 am to 7:30 pm, EST: (800) 334-3666. You may also reach us via e-mail at info@emon.com.

If you have questions, we can handle them quickly and effectively with a telephone call. Please let us try to help you BEFORE you remove your meter. And to help us help you, we ask that you have all relevant information on hand when you call (model or part numbers, nature of difficulty, etc.)

Be sure to forward this manual to the owner after installation is complete, so that they may use it as a reference guide when reading the E-Mon D-Mon meter.

Thank you.

Table Of Contents

	Page	
Section 1.0	Pre-Installation Information	1
Section 2.0	Safety Label Definitions	3
Section 3.0	Precautionary and Safety Information	3
Section 4.0	Meter Installation	4
Section 4.1	Mounting the Meter	4
Section 4.2	Main Power Board Connections	4
Section 4.3	Current Sensor Installation & Wiring	7
Section 4.4	Main Power & Sensor Wiring Diagrams	11
Section 4.5	Line Voltage/Current Sensor Diagnostics	12
Section 5.0	Monitoring multiple loads with one meter	13
Section 6.0	KWh Meter Features & Functions	15
Section 6.1	KWh Meter Display Functions	15
Section 6.2	How to read the kWh Meter	16
Section 6.3	KWh Meter Hardware Functions	17
Section 7.0	KWh/Demand Meter Features & Functions*	19
Section 7.1	KWh/Demand Meter Display Functions	19
Section 7.2	How to read the kWh/Demand Meter	20
Section 7.3	KWh/Demand Meter Set-Up	21
Section 7.4	KWh/Demand Meter Hardware Functions	22
Section 8.0	Preventative/Scheduled Maintenance	24
Section 9.0	Lithium Battery Replacement	24
Section 10.0	Troubleshooting Guide	26
Section 11.0	Frequently Asked Questions	27
Section 12.0	Meter Technical Specifications	28
Section 13.0	Meter Limited Warranty	29

* Applies to meters equipped with the Demand option.

1.0 Pre-Installation Information

The E-Mon D-Mon® Class 2000 kWh/Demand meter is a 3-element meter used to monitor electric power usage of individual loads after the utility meter. **Installation must only be performed by qualified personnel and in accordance with these instructions and all applicable local and national electrical codes.**

E-Mon or its representatives assume no responsibility for damages or injury resulting from the improper installation of this meter.

Meters are supplied in a NEMA 12 steel enclosure appropriate for indoor installation where it will not be affected by the elements, such as moisture and extreme temperatures.

Units designated by the “R” suffix on the model number have an extended environmental operating range and are enclosed in a NEMA 4X enclosure to accommodate outdoor environments.

Verify the input voltage rating and configuration on the meter label to ensure it is suitable for the intended electrical services. Class 2000 meters labeled for 120/208V service **MUST NOT** be installed on service feeds of 277/480V and vice versa.

Verify the current sensors are sized suitably for the load to be monitored. Compare the color of the arrows on the current sensors to the chart below to confirm the correct current sensor is being used.

Sensor Arrow Color Code		Sensor Rating
Brown	-	100 Amp
Red	-	200 Amp
Yellow	-	400 Amp
Black	-	800 Amp
Blue	-	1600 Amp
White/Black	-	3200 Amp

CAUTION: Internal circuit card components are extremely sensitive to electrostatic discharge. Prior to handling or touching internal circuitry, discharge any static buildup on your person. To discharge yourself, touch a grounded metal object such as conduit or an earth grounded metal enclosure.

WARNING: Use of this instrument, Class 2000, in a manner inconsistent with this manual or not specified by the manufacturer in writing, can cause permanent damage to the unit and/or serious injury to the operator. The protection and safety features provided by this equipment may become impaired or otherwise compromised.

NOTE: If any trouble arises during installation or functional verification operations, do not immediately remove unit. Before removing the unit, contact E-Mon's technical support department at (800) 334-3666. E-Mon's technical department will assist you in detailed troubleshooting of the Class 2000 installation.

1.0 Pre-Installation Information (Continued)

Internal Electronic Assemblies

The unit is comprised of two major subassembly boards, Main Power Board and Display Board. All circuit cards are mounted inside a NEMA 12 (standard) or NEMA 4X (optional) enclosure.



Power Supply Board Display Board
(Showing MI Config.)

NOTE: Units are supplied in a NEMA 12 metal enclosure suitable for indoor applications only. Units supplied in the optional NEMA 4X fiberglass enclosure are suitable for either indoor or outdoor applications, within the defined specifications. Refer to Section 12.0 for a definition of suitable environmental conditions for indoor and outdoor units.

Main Power Board

Connections to this board include the MAINS Input Voltage, Current Sensors, external IDR interface and Isolated Pulse Output.

The MAINS input terminals are covered with a protective clear shield for safety purposes. The current sensor assemblies interface to either TB1 (MI configuration) or to three header connectors, TB2, TB3 and TB4 (MI configuration). Each header connector input corresponds to an input voltage phase, so care must be taken to ensure each current sensor is connected to the correct input header.

(Standard Config.)

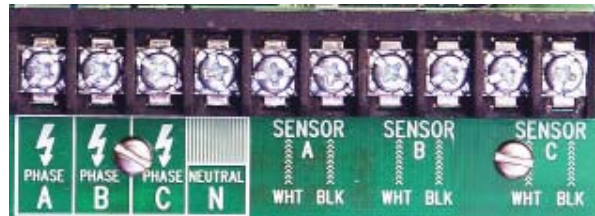

(Optional MI Config.)

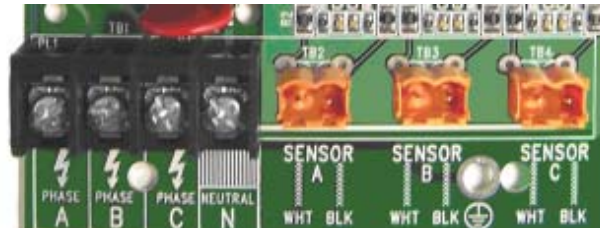

Display Board

The display board connects to the main power board via a flex-ribbon cable and the board is mounted on the inside of the enclosure door. The display board LCD readout indicates the cumulative kWh (on kWh meters) and instantaneous kW value or cumulative kWh, peak demand and instantaneous kW values (on kWh/Demand meters). Additionally, errors such as low battery conditions or sensor error conditions are displayed.

2.0 Safety Label Definitions and Information

The Class 2000 meter may contain one or more of the following labels. Operator(s) should familiarize themselves with the meaning of each label to minimize risk.



The presence of this label is a cautionary indicator identifying a danger risk. The manual should be consulted prior to proceeding.



The presence of this label indicates an electrical shock hazard exists in the location or area where the label is placed. Prior to proceeding, the MAINS power must be disconnected and the manual consulted for safety information.

3.0 Precautionary/Safety Information



CAUTION:

Internal circuit card components are extremely sensitive to electrostatic discharge. Be careful not to touch internal circuitry prior to discharging any static buildup on your person. To discharge yourself, touch a grounded metal object such as conduit or an earth-grounded metal enclosure.



WARNING: High voltages present on main PCB terminal block TB1. Risk of serious injury and/or electrical shock exists. Prior to performing any wiring operations, review all contents of the user manual and de-energize the MAINS power switch. Only qualified personnel should perform installation wiring. Installation wiring must comply with all local and national electrical codes.



WARNING: Failure to ground the enclosure creates a possible shock hazard. Do not operate the Class 2000 meter without a protective earth wire attached securely to the PE terminal screw. After installing protective earth wiring, secure the screw tightly (10 N-m torque.)



WARNING: NEVER open front panel of unit while unit has MAINS power applied. Failure to comply can increase the risk of serious injury and/or electrical shock.

4.0 Meter Installation

4.1 Mounting

STEP 1: Using the appropriate sized mounting hardware, fasten the Class 2000 meter enclosure to the selected mounting surface. The four mounting holes are centered 6.75" H x 4" W. The mounting hole spacing is identical for either the NEMA 12 or NEMA 4X enclosure.

NOTE: Only the NEMA 4X enclosed unit is suitable for outdoor environmental conditions. Units housed in NEMA 12 enclosures must only be installed in indoor environments where it will not be affected by the elements, such as moisture and extreme temperatures.

4.2 Main Power Board Connections

STEP 1: Install a temporary ground for ESD (Electrostatic Discharge) protection. With all circuits de-energized, connect a temporary protective earth ground connection for ESD protection. Prior to performing any unit wiring, be sure to discharge any static on your person.

STEP 2: Install the Class 2000 Protective Earth Ground. Connect an earth ground wire to the Class 2000 protective earth ground terminal screw located on the bottom right side of the main power board. After installing the protective earth ground wire, securely fasten the protective earth ground screw.

WARNING: Failure to attach the protective earth ground wire securely to the enclosure creates a potential shock hazard. Do not operate the Class 2000 meter without a protective earth ground connection securely installed.

STEP 3: Wire Entry

Two openings exist on the unit enclosure, one for 1/2" conduit and one for 3/4" conduit. The 3/4" conduit opening located on the bottom of the enclosure is used to bring in MAINS Power (voltage lines to power meter) and current sensor wiring. The 1/2" conduit opening located on the top of the enclosure is used to interface low voltage signals, such as the IDR interface and isolated pulse output. (Outdoor enclosures equipped with one 3/4" conduit opening on bottom of enclosure only.)

Route the appropriate cabling to and through the respective enclosure opening. The conduit and fittings interfacing the enclosure entrances must be UL listed and properly sized to the enclosure port diameter. The interfacing fitting must use a gasketed seal ring to interface between the conduit fitting and the enclosure entry point. After installing the conduit fitting and conduit, verify that the conduit fittings are aligned properly to their respective enclosure entrance ports and tightened securely to prevent moisture entry. **VERIFY** that each conduit slip nut is securely tightened to its respective conduit fitting.

4.0 Meter Installation (Continued)

4.2 Main Power Board Connections (Continued)

STEP 3: Wire Entry (continued)

Outdoor applications require the use of the optional NEMA 4X enclosure. The same principles outlined for indoor meter installations as defined in the aforementioned paragraph carry over and apply to outdoor installations with one exception. This exception is that the conduit and fittings for outdoor installations require an outdoor material rating.

STEP 4: Unit MAINS Wiring (Voltage Wiring Connections)

Remove the clear shield located over terminal block TB1 on the main power board. This shield can be removed by pressing in on each locking tab located at the top of each standoff. While pressing the tabs inward, lift the shield from the standoffs. Wire each connection to Terminal Block TB1 with stranded wire 14-12 AWG, rated at 600 VAC.

Strip back all wire insulation to expose between 1/4" and 3/8" of the copper conductors. Gently twist each wire to prevent fraying. Insert the conductors into their respective terminal block position and tighten down the terminal block screw to securely fasten the conductor. Terminal block TB1 is clearly labeled PHASE A, PHASE B, PHASE C and NEUTRAL.

Connect the NEUTRAL wire to the appropriate terminal block position.

NOTE: For Delta MAINS input wiring, DO NOT connect the NEUTRAL wire. Remove the terminal block screw for this position.

Connect the AC mains power wires (Phase A, Phase B and Phase C) to their respective positions as labeled on terminal block TB1.

After all conductors are connected to their respective terminal block positions and tightened down, verify that each terminal block screw is securely fastened by gently tugging on each conductor. Verify no conductor wires are frayed or are shorting to adjacent terminal block positions.

STEP 5: External Switch Mechanism/In-Line Fuse Installation

To ensure a safe installation, the Class 2000 meter requires an external switch mechanism, such as a circuit breaker, be installed on the Class 2000 MAINS input wiring. The switch mechanism must be installed in close proximity to the meter and easily reachable for the operator. This device must also be marked as the disconnecting device for the Class 2000 meter.

4.0 Meter Installation (Continued)

4.2 Main Power Board Connections (Continued)

STEP 5: External Switch Mechanism/In-Line Fuse Installation (Continued)

Install 1/10 Amp Slow Activation inline fuses with the suitable voltage rating for each conductor phase at the MAINS input to the meter. The fuses must be labeled to indicate voltage and current rating as well as element characteristics. The fuse element must be slow activating type.

STEP 6: Once the MAINS wiring is complete, replace the clear lexan protective shield over terminal block TB1 and close the enclosure front panel. Secure the enclosure cover using the locking mechanism. Activate the external circuit breaker or equivalent switch to apply AC MAINS power to the unit.

The Class 2000 meter display should turn on and indicate total kWh accumulation reading.

NOTE: The unit display, clock and other critical configuration parameters will be reset once the unit installation and wiring is complete.

STEP 7: Using an AC Voltmeter, verify the input voltage readings are within the limits specified below.

NOTE: For 3-Wire systems, the voltages are measured Phase to Phase. On 4-Wire systems the voltages are measured Phase to Neutral.

Meter Input Voltage Configuration	Nominal Voltage	Limits (+/- 10%)
120/208V, 3 Ph, 4 Wire	120 VAC	108 to 132 VAC
277/480V, 3 Ph, 4 Wire	277 VAC	249 to 305 VAC
240V, 3 Ph, 3 Wire	240 VAC	216 to 264 VAC
480V, 3 Ph, 3 Wire	480 VAC	432 to 528 VAC

STEP 8: Remove power from the unit by de-energizing the external switch.

4.0 Meter Installation (Continued)

4.3 Current Sensor Installation & Wiring

Once the AC voltages have been confirmed to be within acceptable limits, you are ready to install the current sensors. The MAIN power board contains either a 10-position terminal block (TB1) (standard configuration) or three header connectors located at the bottom center of the board, TB2, TB3 and TB4 (MI configuration). If supplied with the TB1 terminal block, the current sensors are connected to the 6 positions on the right side. Both styles are marked with the appropriate phase designation and conductor color. This format must be followed in order for the meter to function correctly.

The Class 2000 meter will be used with one of two basic types of current sensors:

- a. Split-Core Current Sensor: This sensor opens so that it can be attached around the circuit conductor being monitored without interrupting power. Unless otherwise specified, all Class 2000 meters are supplied with this sensor type.
- b. Solid-Core Current Sensor: This sensor does not open and requires the monitored conductor be removed from the circuit to install the current sensor. This type is only supplied when specified at time of order.

NOTE: The unit serial label specifies if the unit is set up for split or solid core current sensors.

Both types of current sensors output a 0-2 VAC signal proportional to the current being measured.

4.0 Meter Installation (Continued)

4.3 Current Sensor Installation & Wiring (Continued)

Installing the Split-Core Current Sensor Assembly

STEP 1: Each phase being monitored will require one two-piece current sensor assembly. Therefore, a three-phase meter will require three (3) assemblies. Open the two-piece current sensor assembly by releasing the nylon clamp using a flat head screwdriver.



STEP 2: Reassemble the current sensor assembly around the conductor(s) to be monitored. Ensure the current sensor halves marked "Load" are both facing the load side of the conductor. The colored arrow will be on the source side of the conductor being monitored and MUST be pointed in a clockwise direction around the conductor being monitored. Tighten the nylon clamp to complete the assembly.

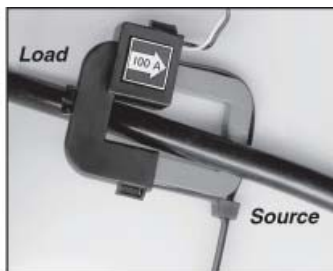

IMPORTANT: When looking from the source side of the conductor(s) being monitored, you should see the arrow on the current sensor assembly. The arrow should be pointing in a clockwise direction around the conductor(s) being monitored. If the arrow is not positioned on the source side, inaccurate readings will result.

4.0 Meter Installation (Continued)

4.3 Current Sensor Installation & Wiring (Continued)

Installing the Solid-Core Current Sensor Assembly

The optional solid-core current sensors can be installed in the same applications as the standard split-core units, however, the conductors that they are monitoring must first be disconnected.

NOTE: Under no circumstances is this operation to take place without shutting off the power to the conductor(s) being monitored.

With the power off, disconnect the conductor from its breaker or terminal. Slide the solid-core current sensor over the conductor, making sure that the indicator on the sensor is pointing in the direction of the load. After this is done, reconnect the conductor and verify that it is properly installed.

Run the black and white wires from the solid-core current sensors and install them according to the standard installation diagram. When this is completed, the power to the monitored conductor can be turned back on.

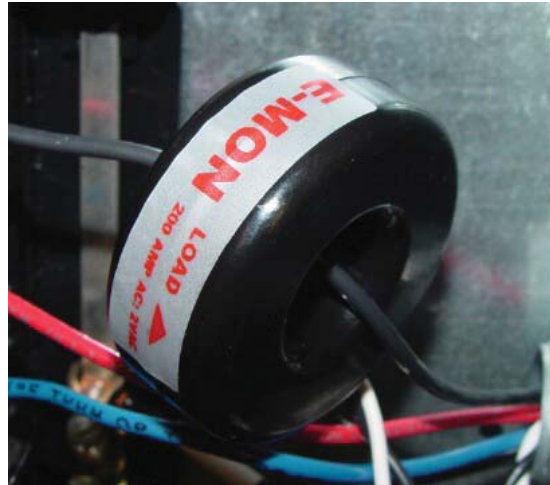

4.0 Meter Installation (Continued)

4.3 Current Sensor Installation & Wiring (Continued)

Current Sensor Wiring

Once all the current sensors are installed on their appropriate phase conductors, you can begin terminating the current sensors on to the Class 2000 main power board.

The current sensor leads can be extended up to 2,000 feet (using #14-22 AWG wire) for remote monitoring applications. Consult your local electrical codes for proper wire sizing (#22 AWG twisted pair wire with a black and white conductor, rated for 600 VAC recommended.)

The current sensor connection points are located on the bottom center of the main power board. If supplied with the terminal block (TB1) (standard configuration), the current sensors are connected to the 6 positions on the right side.

If your meter is equipped with removable current sensor terminal blocks (MI configuration), you can find the current sensor connection points located on the bottom center of the main power board. Three removable plugs exist, one for each current sensor phase input. The header portions of the connectors are labeled TB2, TB3 and TB4. Text silkscreened on each of the connectors instruct you which terminal of the plug is for the white conductor and which terminal is wired to the black conductor. Once each current sensor is wired to its respective plug, insert each plug into the appropriate header.

4.0 Meter Installation (Continued)

4.4 MAINS Line Voltage & Current Sensor Wiring Diagrams

3-Phase, 4-Wire Installation Diagram

Line Voltage Connections: # 14-22 AWG

Sensor Connections: B = Black Lead
W = White Lead

* 1/10 A, 600 VAC inline fuse per conductor.
Littlefuse part number KLDR .100.

** Neutral not used in delta system.
Remove neutral terminal block screw for
Delta systems.

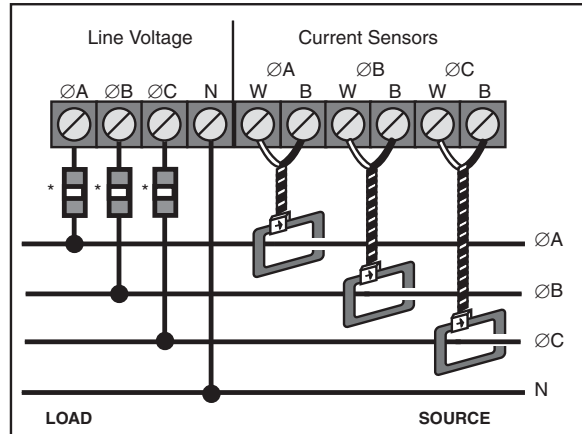

3-Phase, 3-Wire Installation Diagram

Line Voltage Connections: # 14-22 AWG

Sensor Connections: B = Black Lead
W = White Lead

* 1/10 A, 600 VAC inline fuse per conductor.
Littlefuse part number KLDR .100.

** Neutral not used in delta system.
Remove neutral terminal block screw for
Delta Systems.

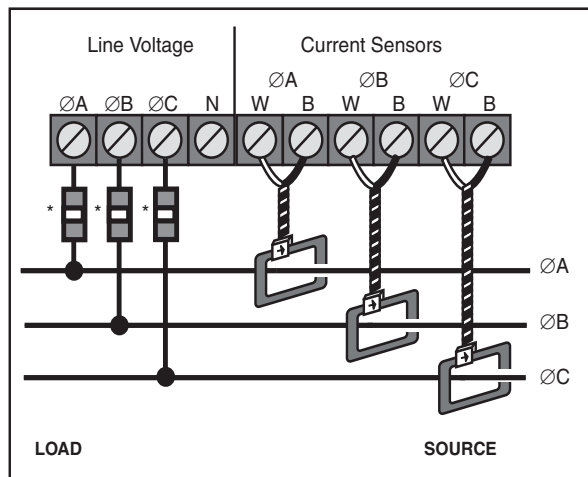

4.0 Meter Installation (Continued)

4.5 Line Voltage/Current Sensor Diagnostics

The three-phase AC MAINS voltage wiring and the current sensor wiring must be connected in the proper phase sequence. If there is a phase sequence error, the display LCD will display a message ‘Check Sensor’ in the upper right hand corner. Additionally, LED D1, Check Sensor, will illuminate if there is a phasing error.

Verify that the AC MAINS voltage wires are all connected to the correct positions on terminal block TB1. Inspect the MAINS input wiring to verify each conductor is terminated at the correct terminal block position. Using an AC voltmeter, measure the AC voltage for each Phase to Neutral terminal and to the Frame ground point.

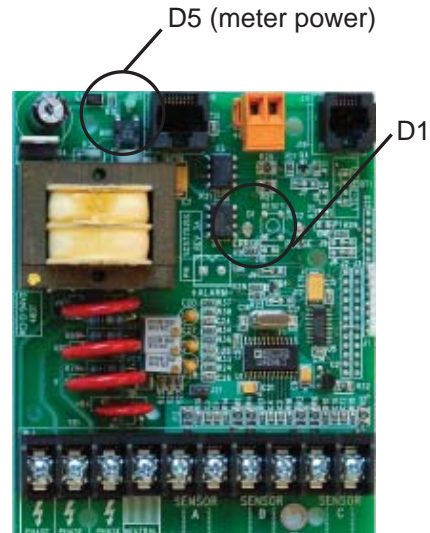

(Main Board Standard Config. Shown)

Verify each current sensor by running at least 1% of the full scale rated current through the conductor being monitored by each phase. (e.g. 2 amp load required for each phase to perform sensor diagnostic procedures.)

- Verify that the current sensor white and black conductors are installed in the correct header positions.
- Verify the current sensors are installed in the correct direction on the conductor being monitored.
- Verify that the current sensor plugs are terminated in the correct header on the Main power board if meter is equipped with removable ST terminal blocks.

If the error messages still haven't been cleared, measure the AC voltage inputs across the plug terminals of each current sensor, individually. Set the AC voltmeter to the 20 Volt scale. If a reading of zero volts is indicated on the voltmeter, check for an open circuit. An open connection could exist at the plug terminals or at a splicing junction. Also verify a tight connection exists between the core halves.

If error message is still appearing, contact E-Mon technical support at (800) 334-3666 for further assistance.

Final Main Board Checks

Once the phase error has been corrected, the Display LCD “Check Sensor” error should extinguish and the Main Power Board LED D1 should extinguish.

5.0 Monitoring Multiple Loads with One Meter

The Class 2000 meter provides extreme flexibility by allowing additional sets of current sensors to be used in parallel so that multiple load locations can be monitored by one meter. This feature allows a totalized display readout from two or more load circuits.

You may use parallel sensors to monitor specific breakers from one panel, specific breakers from more than one panel, two or more complete panels, etc.

When paralleling current sensors, the following rules must be followed for accurate readings:

- Rule 1: Current sensors must be installed in complete sets of three, with a maximum of three sensors installed in parallel per phase.
- Rule 2: All sensors used in parallel must be of the same amperage rating (i.e. 100 amp, 200 amp, etc.) The rating is determined by the current rating (amperage) of the Class 2000 meter. For example, a 200 amp meter must use extra sets of 200 amp current sensors.
- Rule 3: All locations being monitored must have the same power source. A 480 volt meter cannot monitor a 208 volt load nor can a meter monitor two 480 or 208 volt loads if they are from different originating power sources or from different transformers.
- Rule 4: The display readings must be multiplied by the number of sets of current sensors installed. E.g. meter reading of 5 kWh with 2 sets of current sensors... $5 \times 2 = 10$ kWh (actual usage.)

NOTE: One set of current sensors equates to three sensors, one per phase. The multiplier only applies when extra sets of current sensors are installed on one meter. Therefore, if you are using only one set of three sensors (one per phase) the multiplier is not required.

5.0 Monitoring Multiple Loads with One Meter (Continued)

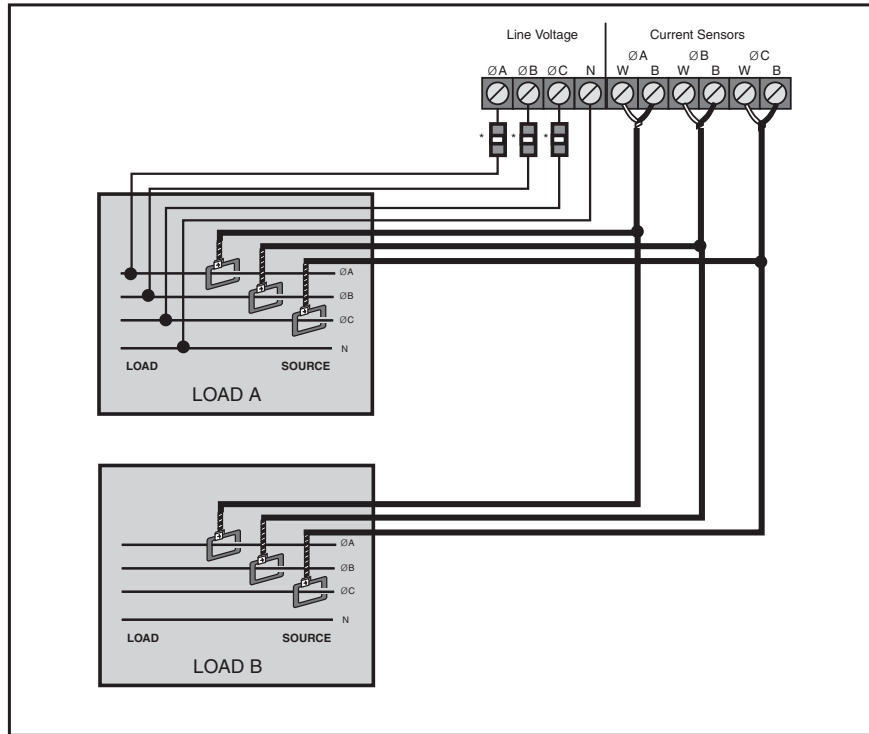

6.0 KWh Meter Features & Functions

6.1 KWh Meter Display Features

Normal Mode (kWh Reading)



The Class 2000 kWh meter display requires no multiplier and shows kilowatt-hours consumed. See section 6.2 for information on calculating cost based on kWh usage.

KW Load Mode (Current Load in kW)



Pressing the “UP” button on the meter display board will switch the display to the Load mode and will show the present load in kW (kilowatts). (Allow 6 seconds for correct reading to stabilize.) This feature is useful to the consumer as it shows the actual load on the meter and can be valuable in showing the effects of large loads-such as air conditioning, electric hot water heaters, and electrical appliances on power consumption. Pressing the “UP” button again returns the meter display to normal mode.

Test Mode

Pressing the “CPU” button on the meter display board will cycle the display through the test mode. The two screens below will be seen.



The first screen activates all the digits and icons on the display. This is to verify that all segments on the display are functional.

The second screen will show the amp rating of the meter. The first digit (on the left side of the dash) will always be zero on the kWh meter. The four digits on the right side of the dash indicate the amp rating.

Upon completion of the cycling, the meter will return to the normal display mode. When the meter is first energized it will automatically cycle through the test screens.

6.0 KWh Meter Features & Functions (Continued)

6.2 How to read the kWh Meter



The Class 2000 kWh meter displays readings in whole numbers, there are no decimals.

To find the dollar cost for the power used by the load(s) being monitored, you must first find out what the cost per kWh is in your area (this cost can be found on your utility electric bill, or call your local utility and ask for their cost per kilowatt hour.) Simply multiply the cost per kWh by the kWh reading from the E-Mon D-Mon meter. The resultant figure is the dollar cost for power used by the load(s) being monitored by this meter.

Example:

8-digit display reading	00000250
Cost per kWh from utility	\$0.12100

$$250 \times \$0.121 = \$30.25$$

NOTE: THE FOLLOWING ONLY APPLIES TO METERS USING MORE THAN ONE SET OF CURRENT SENSORS. For meters using parallel current sensors you must multiply the kWh display reading by the number of sets of current sensors installed.

Example:

$$250 \text{ (meter display reading)} \times 2 \text{ (sets of sensors in parallel)} = 500 \text{ kWh}$$

$$500 \text{ kWh} \times \$0.121 \text{ (utility cost per kWh)} = \$60.50$$

6.0 KWh Meter Features & Functions (Continued)

6.3 KWh Meter Hardware Functions

AMR Jack	8-pin RJ-45-used to connect kWh meter to the E-Mon Energy automatic meter reading system.
Peripheral Jack	6-pin RJ-11-used to interface with E-Mon meter options such as the P2 Pulser or D/A Converter.
Check Sensor LED	When lit, indicates that the current sensor is backwards or on the incorrect phase.
Meter Pulse LED	Blinks to show the meter load. Blink rate increases with load.
Power On LED	When lit, indicates power to meter is on.
Real-Time Load PB	Press (UP) once and wait 6 seconds to display present load in kW, press again to return to standard kWh display (update is not instantaneous.)
Reset PB	Press (RESET) to reset display to zero.
Display Test PB	Press (CPU) to test display. Shows "88888888" then amp rating of meter.
DIP Switch	Meter set-up. Used ONLY by E-Mon factory personnel.
CPU Active LED	One blink per second indicates normal operation.

Main circuit board located inside meter enclosure

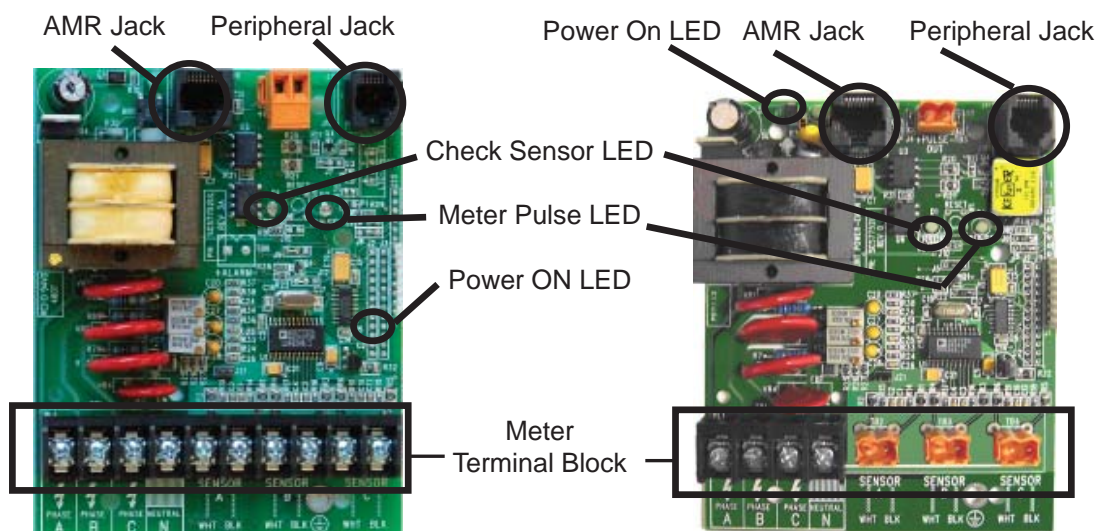

Standard Configuration
Page 17

MI Configuration

6.0 KWh Meter Features & Functions (Continued)

6.3 KWh Meter Hardware Functions (Continued)

Circuit board located inside door of meter enclosure.

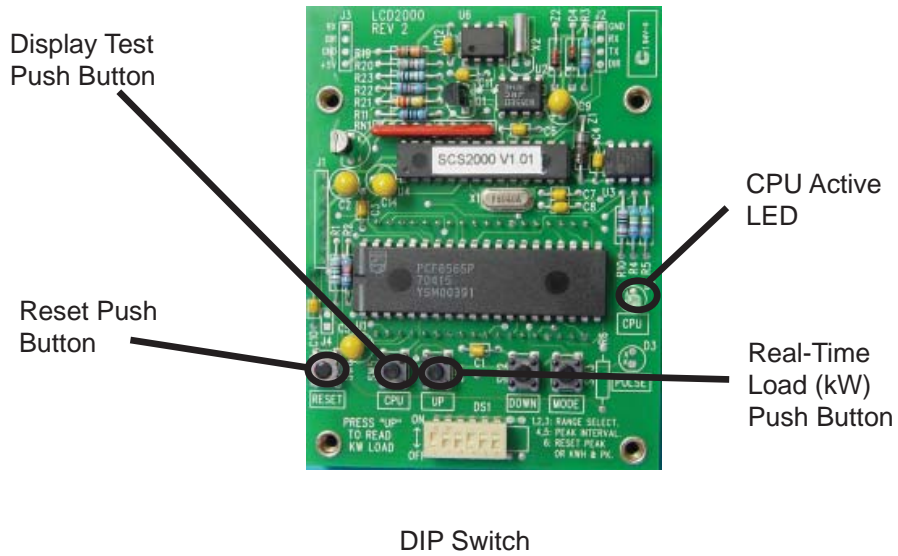

7.0 KWh/Demand Meter Features & Functions
(Only applies to meters ordered with the Demand Option)

7.1 *KWh/Demand Meter Display Functions*

The Class 2000 kWh/Demand meter has a single display window that cycles through the energy data screens. The meter will cycle through four (4) separate screens. The screens are described below.

00004723_{kWh}

KWh display shows the amount of energy consumed in kilowatt hours (kWh). Reading is in whole numbers, there are no decimals and the meter requires no multipliers.

000059.3_{kW}

KW display shows the electrical Demand in kilowatts (kW). Demand interval is either 15 minutes or 30 minutes. (Default is 15 minutes.)

04-22-08

Date display shows the date of the demand (kW) peak.

12-30

Time display shows the time of the day that the demand peak occurred.

7.0 KWh/Demand Meter Features & Functions
(Only applies to meters ordered with the Demand Option)

7.2 How to Read the kWh/Demand Meter

KWh Reading



The Class 2000 kWh meter displays readings in whole numbers, there are no decimals.

To find the dollar cost for the power used by the load(s) being monitored, you must first find out what the cost per kWh is in your area (this cost can be found on your utility electric bill, or call your local utility and ask for their cost per kilowatt hour.) Simply multiply the cost per kWh by the kWh reading from the E-Mon D-Mon meter. The resultant figure is the dollar cost for power used by the load(s) being monitored by this meter.

Example:

8-digit display reading	00000250
Cost per kWh from utility	\$0.12100

$$250 \times \$0.121 = \$30.25$$

KW (Demand) Reading



The kW (Demand) reading is the peak usage over a specified time period (15 minute standard, 30 minute optional). While kWh costs are interpreted as cents, Kilowatt costs are usually represented in dollars, and interpretation of demand costs are based on your utility's tariff and rate structures. You will need to contact your utility to see how your utility structures their kilowatt demand charges to ensure proper allocation of costs utilizing data from the E-Mon D-Mon meter.

NOTE: THE FOLLOWING ONLY APPLIES TO METERS USING MORE THAN ONE SET OF CURRENT SENSORS. For meters using parallel current sensors you must multiply the kWh display reading by the number of sets of current sensors installed.

Example:

$$250 \text{ (meter display reading)} \times 2 \text{ (sets of sensors in parallel)} = 500 \text{ kWh}$$

$$500 \text{ kWh} \times \$0.121 \text{ (utility cost per kWh)} = \$60.50$$

7.0 KWh/Demand Meter Features & Functions
(Only applies to meters ordered with the Demand Option)

7.3 KWh/Demand Display Set-Up

The demand meter display is set-up using the Mode Select, Up and Down buttons located on the meter display board which is mounted on the door inside the meter enclosure. The CPU Reset button may also be utilized for certain functions. (See Section 7.4 for details on button locations.)

STEP 1: Date Setting

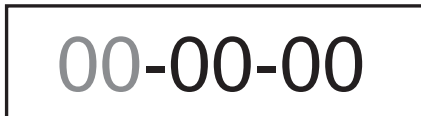

Press the Mode Select button and the display screen shown will appear. The date is entered MM-DD-YY. A zero will proceed a single digit entry. Using the Up and Down buttons, enter the correct numbers. After entering the correct number in the first set of digits, press the Mode Select button to move to the next set of digits. When completed, pressing the Mode Select button will advance the display to the next screen.

STEP 2: Day of Week and Time Setting



Time shown is Wednesday, 10:08 pm

The first section of the next screen calls for the entry of the recent day of the week. Using the Up and Down buttons, enter “1” for Sunday, “2” for Monday, “3” for Tuesday, “4” for Wednesday, “5” for Thursday, “6” for Friday or “7” for Saturday. This is important so the meter can automatically keep track of daylight savings time. Using the Mode Select button, move to the next field where the hour is entered through the Up and Down buttons. As the meter uses a 24 hour clock, this number will be from 1 to 24. (eg. 2:00pm=14). The final field will be the minute display which is also entered by pressing the Up and Down buttons. Again, press the Mode Select button to move to the final display screen.

NOTE: When the meter is first energized, or after pressing the CPU Reset button, the display will appear as seen below:

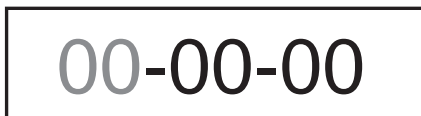

7.0 KWh/Demand Meter Features & Functions
(Only applies to meters ordered with the Demand Option)

7.4 KWh/Demand Meter Hardware Functions

AMR Jack	8-pin RJ-45-used to connect kWh meter to the E-Mon Energy automatic meter reading system.
Peripheral Jack	6-pin RJ-11-used to interface with E-Mon meter options such as the P2 Pulser or D/A Converter.
Check Sensor LED	When lit, indicates that the current sensor is backwards or on the incorrect phase.
Meter Pulse LED	Blinks to show the meter load. Blink rate increases with load.
Power On LED	When lit, indicates power to meter is on.
Real-Time Load PB	Press (UP) once and wait 6 seconds to display present load in kW, press again to return to standard kWh display (update is not instantaneous.)
Reset PB	Press (RESET) to reset display to zero.
Display Test PB	Press (CPU) to test display. Shows “88888888” then amp rating of meter.
DIP Switch	Meter set-up. Used ONLY by E-Mon factory personnel.
CPU Active LED	One blink per second indicates normal operation.

Main circuit board located inside meter enclosure

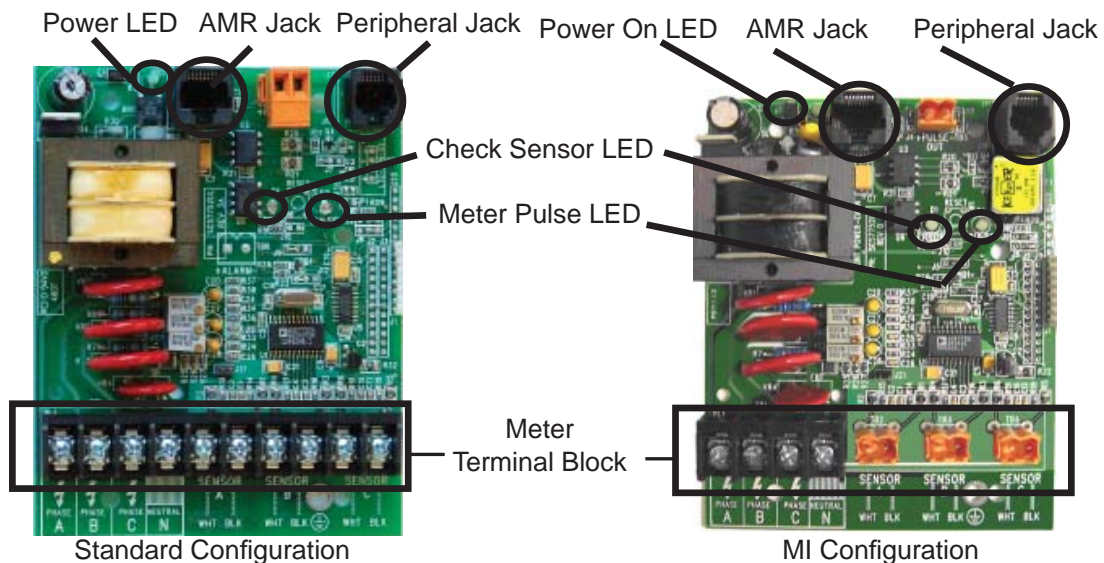

7.0 KWh/Demand Meter Features & Functions (continued)
(Only applies to meters ordered with the Demand Option)

7.4 KWh/Demand Meter Hardware Functions

CPU Active	LED (D1) blinks indicating the CPU is active and operating.
Mode Select	Button used to select adjustment mode when setting up the meter (clock adjust, date adjust, input select.)
Down Button	Used when adjusting time and date for meter display.
Dip Switch	For use by E-Mon factory personnel only.
Up Button	Used when adjusting time and date for meter display.
CPU Reset	Resets the CPU; Used by field service personnel.
Meter Reset	All meter display readings reset to zero.

The picture below shows the various hardware points on the KWh/Demand meter display board that are utilized when setting up the meter for operation. The board is located on the inside of the door of the meter and is accessible by opening the enclosure. A padlocking hasp is provided on the meter enclosure to prevent unauthorized access. The functions of these hardware points are outlined above.

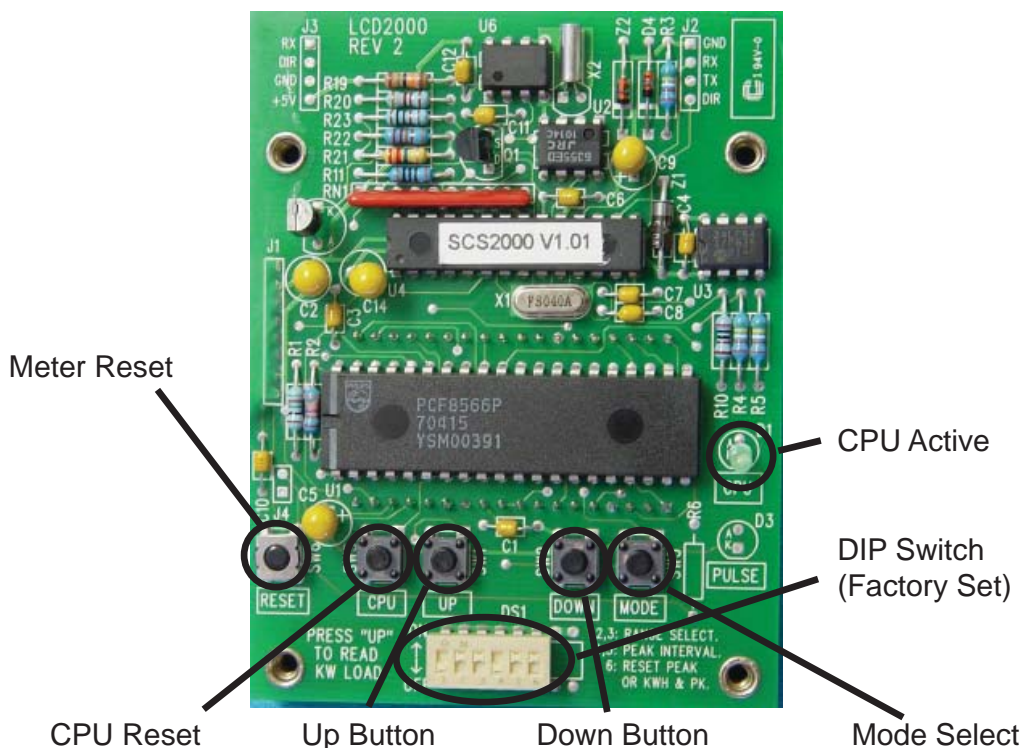

8.0 Preventative/Scheduled Maintenance

The Class 2000 kWh/Demand meter is shipped in a calibrated, tested and fully functional condition.

- All potentiometers are sealed. No field adjustments are required.
- No preventative or scheduled maintenance is required.
- No cleaning or decontamination procedures are required for this instrument.

9.0 Lithium Battery Replacement Instructions

The Class 2000 kWh/Demand meter has a Lithium Battery Cell, which is used to retain the contents of SRAM and the RTC during power outages. The battery has a life expectancy of greater than 8 years.

Battery Specifications:	25 Degrees Celsius
Nominal Working Voltage:	3.5 VDC Output
Nominal Current Capacity:	350 mAHr
Cell Chemical:	Lithium-Thionyl Chloride
Operating Temperature Range:	-40 to +95 Degrees Celsius
Manufacturer:	Eagle-Picher
Manufacturer's Part Number:	LTC-3PN-S2

WARNING: Only replace battery with exact manufacturer and manufacturer's part number specified above.



The battery cell is mounted in a socket on the right side of the main power board. Should the battery drop below 2.4 VDC in capacity, the display will illuminate a battery symbol on the left margin indicating a low battery condition. Additionally, the internal unit firmware will set a flag indicating the low battery condition. Use the following procedure to replace the lithium battery cell.

CAUTION: The battery is not completely discharged, therefore DO NOT short the terminals on the battery with any conductive material.

CAUTION: Internal circuit card components are extremely sensitive to electrostatic discharge. Be careful not to touch internal circuitry prior to discharging any static buildup on your person. To discharge yourself, touch a grounded metal object such as conduit or a metal enclosure exterior.

9.0 Lithium Battery Replacement Instructions (Continued)

STEP 1: Disconnect power from the meter at the unit external circuit breaker.

STEP 2: Remove the battery from its socket and place on a non-conductive surface.

STEP 3: Install new battery into the PCB battery socket.

NOTE: Observe polarity of battery terminals. Be sure to align battery terminal polarities with pcb silkscreen markings. No damage to unit or battery will occur if battery is inadvertently installed in the wrong direction.

STEP 4: Visually inspect new battery to verify that all leads are fully inserted into their respective socket positions.

STEP 5: Dispose of the used battery in accordance with the manufacturers' (Eagle Picher) instructions.

10.0 Troubleshooting

The Class 2000 kWh/Demand meter is calibrated and tested at the factory before being packaged and shipped. If installed properly and in accordance with these installation instructions, your Class 2000 meter should provide years of trouble-free service. If the meter should not function, the following guide will assist in troubleshooting the installation.

Problem	Procedure to follow
1. Display window is blank.	A. Check wiring to voltage terminals. B. Check circuit breakers or fuses. C. Verify that the power is turned on. D. Test source for correct voltage.
2. Display shows incomplete figures or numbers other than zeros when power is turned on.	A. Press RESET button located on door inside meter enclosure (5 sec.)
3. Display reading all zeros (00000000)	A. Determine if load is sufficient to update the display. B. Check RESET button to ensure there are no wires or other objects pressing against it when the door is closed. C. Check the current sensors for installation and polarity. D. Be sure the current and voltage inputs have the proper phase relationship. E. Check wiring to voltage terminals. F. Check circuit breaker or fuses. G. Test source for correct voltage.
4. Display reads only a fraction of consumption	A. Check the supply voltage to be sure that it is on continuously 24 hrs/day. B. Check the current sensors for installation and polarity. C. Check sensor wiring to the terminal strip in meter (color coding B & W.)

NOTE: If you still need assistance after performing the above troubleshooting procedures, do not remove the unit. Before removing the unit, contact E-Mon's technical support department at (800) 334-3666, our support experts will assist you in detailed troubleshooting of the meter installation and assist you in getting the unit operating correctly.

11.0 Frequently Asked Questions

- Q. When providing line voltage to the meter, can I tap off of the same breaker I am monitoring?**
A. Yes, the voltage can be pulled from the same breaker being monitored.
- Q. Can the meter's line voltage wires be run in the same conduit as the sensor leads?**
A. Yes, there will be no effect on the meter if the sensor leads and line voltage wires are run in the same conduit.
- Q. Can the meter communication wires and line voltage wires be run in the same conduit?**
A. It is NOT recommended to run these wires together due to noise concerns and their effects on the communications signal integrity. Communication wires can be routed separately using the 1/2" conduit port.
- Q. How do I find the cost for kWh and kW to bill my tenants?**
A. Your local utility bill should list the cost per kWh and kW. If not, simply call your utility and ask them to provide you with the cost per kWh and kW.
- Q. What size wire do I use for the line voltage leads?**
A. These wires are normally #14 AWG, but be sure to consult your local electrical codes for proper sizing requirements.
- Q. What size wire should I use to extend the current sensor leads?**
A. These wires are normally sized at #14-22 AWG, twisted pair arrangement. Consult your local electrical codes for proper sizing requirements.
- Q. The load I need to monitor has parallel feeds. How do I install the current sensors for this application?**
A. There are two ways you can monitor parallel feeds. One method is to clamp the sensors around all feed wires for each phase (no additional reading multiplier required). The second way to monitor parallel feeds is to clamp the sensor around one of the feed wires for each phase, and when you read the kWh meter the final reading must be multiplied by the number of feed wires for each phase.
- Q. I have two subpanels I would like to monitor with one meter. These subpanels are fed by different transformers in the building. Can I parallel sensors and monitor both panels with one meter?**
A. No. These panels cannot be monitored by one meter because they are different power sources. When you parallel current sensors, all loads must be from the same voltage source.
- Q. I have 5 breakers in one subpanel I would like to monitor with one meter. Can this be done without having to parallel current sensors?**
A. Yes. Simply run all the breaker wires through one set of current sensors. Make sure all A phase circuits are run through the A phase sensor, and the same for B & C phases. The meter should be sized by the highest amount of current being monitored by one sensor.
- Q. I've gone through the troubleshooting guides and I still can't get my meter to work. What should I do?**
A. Before removing the unit, contact E-Mon's technical support department at (800) 334-3666. Our technical support experts will assist you in detailed troubleshooting of the meter installation and assist you in getting the meter functional without having to remove and return the unit.

12.0 Meter Technical Specifications

Ordering Information: Define input voltage, current sensor rating (amperage) and options.

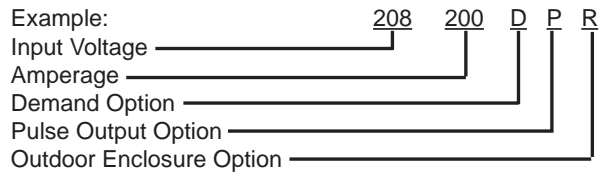

Input Voltage Configuration:	3-Wire (Delta) or 4-Wire (Wye)
MAINS Voltage Input:	Up to 480 VAC RMS Available
Input Power:	6VA Maximum Rating
Current Sensor Rating:	Up to 3200 Amp RMS AC Available
Power Factor:	.5 leading or lagging
Line Frequency:	50-60 Hz
Metering Accuracy:	Certified to ANSI C12.16 (+/- 1% from 1% to 100% of rated load)
Voltage Operating Range:	+/- 10% of rated load
Temperature Range (Standard indoor enclosure):	-20 degrees C to +50 degrees C
Temperature Range: (NEMA 4X outdoor enclosure):	-20 degrees C to +70 degrees C
Relative Humidity Range:	0-95% Non-Condensing
Altitude:	2000 meters maximum
Voltage Overload:	+25% Continuously; +100% for 20 Cycles
Current Sensor Overload:	100% for 1 minute without damaging meter
Pollution Degree:	Degree 2 in accordance with IEC 664
Installation (Overvoltage) Category:	Category III
Measurement Category:	Category III
Indoor Housing Rating (Standard):	NEMA 12
Outdoor Housing Rating (Optional):	NEMA 4X
Display Readout:	KWh Accumulated, Peak Demand, Instantaneous kWh
Standard Ranges:	4-Wire Wye, 120/208 VAC: 100, 200, 400, 800, 1600 and 3200 Amp
	2 Phase, 120/240 VAC: 100, 200, 400, 800, 1600 and 3200 Amp
	4-Wire Wye, 277/480 VAC: 100, 200, 400, 800, 1600 and 3200 Amp
	3-Wire Delta, 220/240 VAC: 100, 200, 400, 800, 1600 and 3200 Amp
	3-Wire Delta, 480 VAC: 100, 200, 400, 800, 1600 and 3200 Amp
IDR Interface Port:	Cable Specifications: UL Listed/Rated Telephone Cord, 6-conductor 300 VAC, stranded conductors, 22-26 AWG.
	Input/Output Voltage: +5 VDC/18 VAC
	Cable Connector: RJ-45 male IDC
	Ckt Input Isolation: 5.3K VAC for 1 Minute
	Ckt Output Isolation: 2.5K VAC
Isolated Pulse/Alarm Outputs (TB5, TB6):	Output Voltage Potential: 0 VDC to +5 VDC Logic Levels
	Mating Plug Connector: Weidmuller PN: 152876
	Signal Isolation Voltage: 5.3K VAC for 1 Minute
Recommended in-Line Fuse:	Manufacturer: Littlefuse
	Mfg Part No.: KLDR.100
	Rating: 100mA, Time Delay, 600 VAC Cartridge Fuse
Battery Cell:	Description: Non-rechargeable cell used for memory retention.
	Manufacturer: Eagle-Picher
	Mfg Part No.: LTC-3PN-S2
	Working Voltage: 3.5 VDC
	Current Capacity: 350mAHr
	Electrolyte: Lithium Thionyl Nitrate

13.0 Meter Limited Warranty

Subject to the exclusions listed below, E-Mon will either repair or replace (at its option) any product that it manufactures and which contains a defect in material or workmanship.

The following exclusions apply:

1. This Limited Warranty is only effective for a period of (5) five years following the date of manufacture when installed in accordance with manufacturer's instructions by qualified personnel.
2. E-Mon must be notified of the defect within ninety (90) days after the defect becomes apparent or known.
3. Buyer's remedies shall be limited to repair or replacement of the product or component which failed to conform to E-mon's express warranty set forth above.
4. Buyer shall be responsible for all freight costs and shall bear all risk of loss or damage to returned goods while in transit.
5. This Limited Warranty does not cover installation, removal, reinstallation, or labor costs, and excludes normal wear and tear. Buyer shall provide labor for the removal of the defective component or item and installation of its replacement at no charge to E-Mon.
6. This Limited Warranty does not cover any product if: (i) a product is altered or modified from its original manufactured condition, (ii) any repairs, alterations or other work has been performed by Buyer or others on such item, other than work performed with E-Mon's authorization and according to its approved procedures; (iii) the alleged defect is a result of abuse, misuse, improper maintenance, improper installation, accident or the negligence of any party; (iv) damaged as a result of events beyond E-Mon's control or other force majeure events or (v) used in conjunction with equipment, components, accessories, parts or materials not supplied or approved by E-Mon.
7. This Limited Warranty is limited to the obligation to repair or replace the manufactured product. This is the sole and exclusive remedy for any breach of warranty. IN NO EVENT SHALL E-MON BE LIABLE FOR ANY INDIRECT, INCIDENTAL, SPECIAL, CONSEQUENTIAL OR PUNITIVE DAMAGES (INCLUDING ANY DAMAGE FOR LOST PROFITS) ARISING OUT OF OR IN CONNECTION WITH THE FURNISHING OF PRODUCTS, PARTS OR SERVICES, OR THE PERFORMANCE, USE OF, OR INABILITY TO USE ANY PRODUCTS, PARTS OR SERVICES, SALE OF OR OTHERWISE, WHETHER BASED IN CONTRACT, WARRANTY, TORT, INCLUDING WITHOUT LIMITATION, NEGLIGENCE, OR ANY OTHER LEGAL OR EQUITABLE THEORY.
8. EXCEPT AS EXPRESSLY PROVIDED HEREIN, E-MON MAKES NO WARRANTY OF ANY KIND, EXPRESS OR IMPLIED WITH RESPECT TO ANY PRODUCTS, PARTS OR SERVICES PROVIDED BY E-MON INCLUDING, BUT NOT LIMITED TO, THE IMPLIED WARRANTIES OF MERCHANTABILITY AND FITNESS FOR A PARTICULAR PURPOSE. PRODUCTS OR COMPONENTS DISTRIBUTED, BUT NOT MANUFACTURED, BY E-MON ARE NOT WARRANTED BY E-MON AND BUYER MUST INSTEAD RELY ON THE REPRESENTATIONS AND WARRANTIES, IF ANY, PROVIDED DIRECTLY TO THE BUYER BY THE MANUFACTURER OF SUCH PRODUCT OR COMPONENT.